

SHARK 281 SXI EVO

The semi-automatic band sawing machine ideal for the cut of solid bars that combines strength with easy handling



□ SEMIAUTOMATIC SAW

□ ELECTROHYDRAULIC

□ BAND BLADE

□ FOR +60° CUTTING

CUTTING RANGE

	●	■	▬
0° / mm	250	230	280 x 200
+45° / mm	190	180	180 x 180
+60° / mm	120	110	110 x 110
Max. open vice	285 mm		

PERFORMANCE CHARACTERISTICS

Blade size	2950 x 27 x 0.9 mm
Blade speed	40 / 80 m/min
Blade motor	1.5 / 1.8 Kw
Capacity of coolant tank	13 L
Capacity of the hydraulic tank	2.5 L
Total input power	2.176 Kw

WEIGHT AND DIMENSIONS

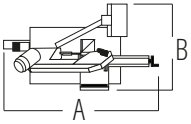
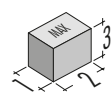
Height of working table	857 mm
Weight	435 kg
	A = 2000 mm B = 1000 mm
	1 = 1000 mm 2 = 1700 mm 3 = 1840 mm